

MEC E-Z PRIME "S"

*FOR THE
SUPER 600, 650,
GRABBER, HUSTLER,
9000G & 9000H*

**COMPLETELY AUTOMATIC
PRIMER FEED**

INSTALLATION OF E-Z PRIMER FEED "S"

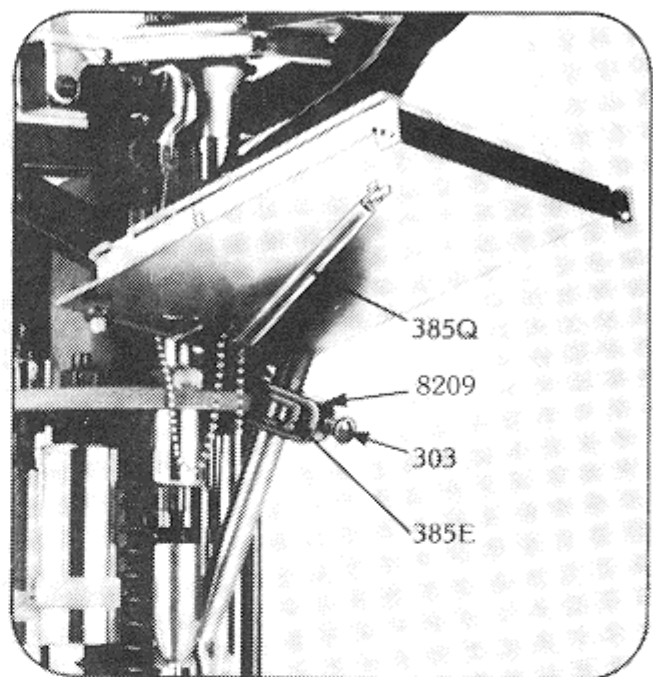
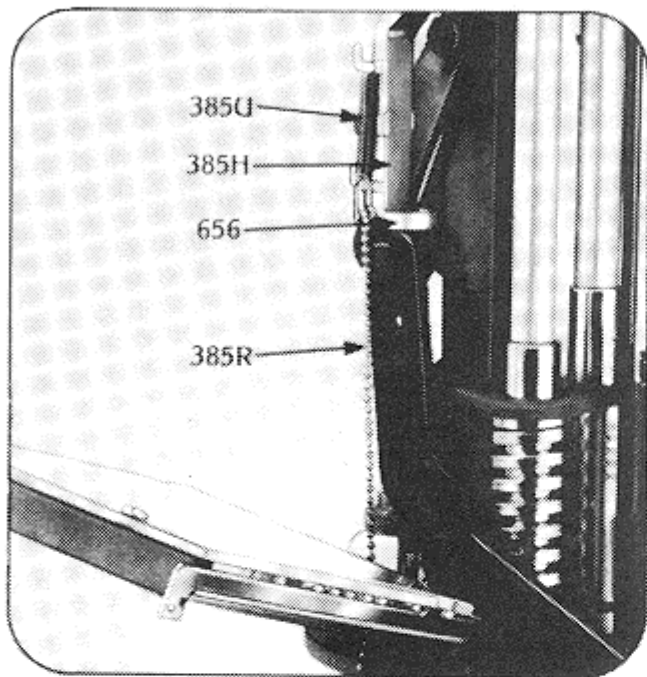

Tools required: 7/16 box wrench, screw driver.

1. For Super 600 or 650, position spring clip, part #385H, against the base (foot) of knockout bracket, item 78, part #656. Snap spring clip into position.
2. Attach override spring, part #8209, to upper projection of spring keeper, part #385H; allow actuator chain, part #385R, to hang free.
3. Position feed tube clamp, part #385C, in slot provided in turret. Position washer, part #609F, under head of bolt and #685H under frame and turn finger tight.
4. Depress handle. Insert retaining clip, part #385E, in bracket. Insert tube in bracket and pivot curved side of tray against loosely hanging chain. Tighten stop screw, part #303, finger tight when tube touches carrier with handle completely depressed.

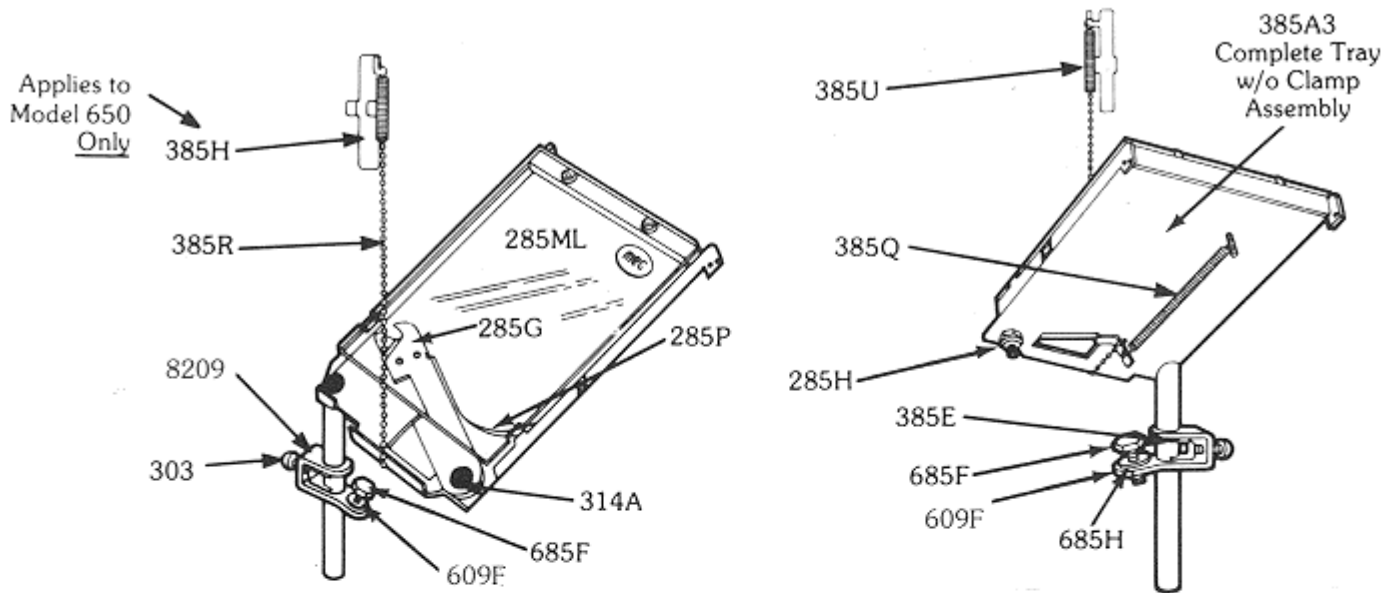

5. Raise handle, place spent primer in hole in carrier, depress handle and visually confirm alignment of tube with primer in carrier. If alignment is satisfactory, tighten #303 screw.
6. With handle depressed, attach chain in upper slot of finger on the underside of tray after stretching override spring, part #385U, 1/4". (Spring must be under 1/4" tension when handle is depressed.)
7. Open cover, position primer box face down on tray. Slide box cover from right to left, leaving liner and primers. Carefully lift liner allowing primers to remain on tray, close cover.

Primer feed should now be operative, depositing a primer in the carrier with each stroke of the handle.

TROUBLE SHOOTING

If primers fail to drop when handle reaches bottom of stroke, tighten chain in increments of one bead until satisfactory operation is obtained.

If primers drop too early and tend to tip in the opening of the carrier, loosen chain in increments of one bead to arrive at the proper adjustment.

To interrupt the feeding of the primers, detach spring #385U from #385H. Attach spring to #385H to resume feed.

If primers fail to slide properly down the tray, polish tray using furniture polish or silicone gun cloth.

If primers turn over in tray, cover must be tightened. Lift cover and bend side tabs of tray in slightly. Snap cover back in position.



MAYVILLE ENGINEERING COMPANY, INC.

715 South Street • Mayville, Wisconsin 53050
(920) 387-4500 • FAX (920) 387-5802