

Frankford Arsenal

Reloading Tools



TM

Model SS-99TM Reloading Press

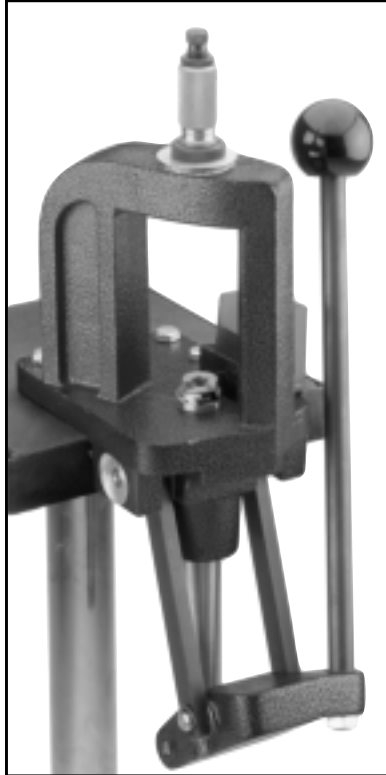

Instructions

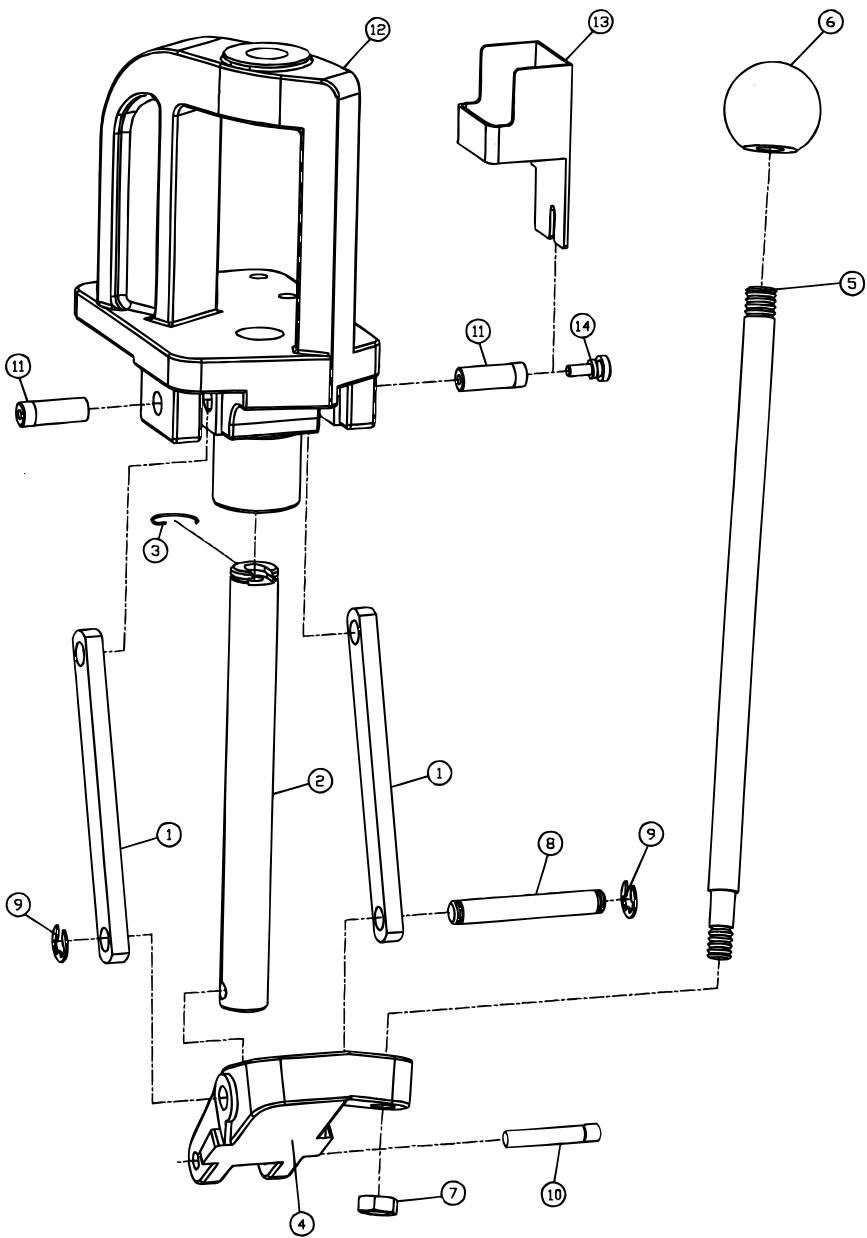

Parts List

| Key | Part Number | Description | Quantity |
|-----|-------------|-----------------------------------|----------|
| 1. | 122-921 | Link Arm | 2 |
| 2. | 180-319 | Ram..... | 1 |
| 3. | 194-389 | Shellholder Retainer Spring | 1 |
| 4. | 303-962 | Toggle Block | 1 |
| 5. | 332-821 | Handle | 1 |
| 6. | 367-940 | Ball Knob | 1 |
| 7. | 389-430 | 1/2"-20 Jam Nut | 1 |
| 8. | 472-137 | Lower Link Pin | 1 |
| 9. | 616-108 | Link Pin Clip | 2 |
| 10. | 755-494 | Ram/Toggle Pin..... | 1 |
| 11. | 780-477 | Upper Link Pin | 2 |
| 12. | 783-904 | Frame | 1 |
| 13. | 784-492 | Primer Catcher | 1 |
| 14. | 796-428 | 1/4"-20 Thumb Screw..... | 1 |
| ** | 146-449 | 5/16-18 UNC x 2 1/2" Bolts | 3 |
| ** | 181-718 | 5/16" Flat Washers..... | 6 |
| ** | 193-259 | 5/16"-18 UNC Hex Nuts | 3 |

** Not Shown in Drawing

Model SS-99 Reloading Press Instructions

Introduction

Congratulations on your selection of the Frankford Arsenal Model SS-99™ Reloading Press. Your new press is one of the finest single-stage reloading presses available to reloaders today. This press is the end result of years of research and development and has been produced under rigid manufacturing and quality control standards. It has been designed specifically to handle the stresses of heavy-duty reloading and case forming so that normal reloading activities require only minimal effort. The modern ergonomic press design combines the most desirable features demanded by today's single stage press users, including a larger than normal frame opening, sized to handle an extremely wide range of rifle and pistol calibers (standard and wild-cat).

Rifle - .17 caliber through and including .460 Weatherby Magnum, as well as British calibers up through the 3 1/4" length Nitro Express cartridges

Pistol - 25 ACP through 50AE.

Disclaimer

Since Frankford Arsenal has no control over the choice of reloading components (ie., cases, bullets, primers, and powder), the manner in which they are assembled, the use of the press, or the firearms in which the resulting reloaded ammunition may be used, no responsibility, either expressed or implied, is assumed for the use of ammunition reloaded with this press.

Mounting and Assembly

Your new Frankford Arsenal reloading press is shipped completely assembled and ready to use with the exception of the operating handle and primer catcher. Prior to use, the press should be securely mounted to a solid bench. The bench top should be rigid and at least 3/4" thick. Mount and assemble the press as follows.

- Carefully position the press against the edge of the bench top in a convenient location. The back of the ram support column and link arm supports should be flush with the edge of the bench top. The press frame bottom should also set flush against the bench top.
- Verify that the toggle block will not interfere with any portion of the bench throughout its entire range of motion.
- With the press in the desired mounting location, mark the position of the mounting holes using a pencil or punch.
- Remove the press and drill the 3 mounting holes in the bench top using a 3/8" drill bit.
- Secure the press assembly to the bench with the three 5/16" bolts (provided) using 1/2" box end wrenches or sockets. Be sure to use the flat washers (provided) above the press frame and below the bench top.
- Slide the handle assembly into the hole in the toggle block. Secure the handle with the 1/2"-20 jam nut using a 3/4" box end wrench or socket.
- Screw the 1/4"-20 nylon thumbscrew into the threaded hole in the right side, upper link pin. Back out the thumbscrew slightly. Slide the primer catcher slot downward over the thumbscrew, with the primer catcher box facing the ram, until the primer catcher rests firmly against the top of the frame. Secure by hand tightening the thumbscrew. Do not over-tighten.

Maintenance and Lubrication

The press has been lubricated at the factory and is ready for use. However, the ram and link pins should be lubricated periodically with **SAE 30** weight motor oil or equivalent. Never use penetrating lubricants, aerosol sprays, or solvent type lubricants, such as WD-40™ or Break Free™. The press should be cleaned prior to lubrication to remove grit and other residue. If rust spots appear on unpainted surfaces, swab with gun oil and wipe dry. If the press is to be used in a damp area, all non-painted surfaces should be protected with a thin film of oil. Painted surfaces may be cleaned with a damp cloth.

The primer catcher should be emptied periodically. Wipe away any accumulated grit and primer residue from around the ram as well as any accumulations within the primer ejector slot of the ram. Wipe up any excess oil that may also accumulate in the primer ejector slot.

Die Installation

The top of the press frame is threaded to accept all standard 7/8"-14 thread reloading dies. Since die adjustment procedures vary with the brand of dies used, it is recommended that you first refer to the user instructions provided with your particular die set.

Once adjusted, the die lock ring (provided with the die) should always be tightened to secure the die in place. To minimize case neck and bullet runout, always run an empty case or case with a seated bullet up into the die prior to tightening the die lock ring.

Note: Sizing dies should only be turned down enough to take up the slack in the linkage system. A toggle type compound linkage system can literally develop tons of force (at its toggle point) sufficient to spring any press frame. Screwing the sizing die down more than necessary (well past top dead center) can potentially damage the shellholder, dies, and even the press if the ram is forced to top dead center under these conditions.

Shellholder Installation

Shellholders are caliber specific and should be selected on the basis of the caliber of dies used. The press ram is designed to use most popular brands of universal shellholders. Install by sliding the shellholder into the slot at the top of the ram until it snaps in place. It is recommended that you rotate the shellholder slightly clockwise for easier access (about 60 degrees so that the slot in the shellholder is perpendicular to the top of the frame). To remove the shellholder, simply pull forward (away from the bench).

Priming

Because hand priming tools offer the reloader a safer and more consistent "feel" for seating primers, the Frankford Arsenal Model SS-99 press does not come with a universal priming arm. Universal priming arms lack the proper mechanical advantage and tactile feel necessary for consistent primer seating depth, are cumbersome to use, and due to necessary frame offsets and milled slots required for installation, compromise press frame structural integrity. If a press-mounted priming system is desired, any of the many ram priming systems on the market can be installed on the Model SS-99.

Warning



The Midway press has been designed specifically to handle the stresses of heavy-duty reloading and case forming and is not recommended for use in bullet swaging operations.

Note this press uses a positive mechanical stop in the compound linkage system to terminate ram motion at top dead center. To prevent damage to the press, dies, and shellholder, no further pressure should be applied to the operating handle once this stop is reached.

The use of a cheater bar (or a pipe) on the press handle to gain additional mechanical advantage may overstress press components. Evidence of such abuse will void the warranty.

Troubleshooting Guide

A summary of common reloading problems and causes are listed below.

Case Insertion

1. Problem: Case will not slide into shellholder.

Possible Cause:

- Dirt in shellholder pocket.
- Damaged shellholder.
- Wrong shellholder.
- Case has bent rim.
- Cases not within SAAMI specs.
- High primer.

Resizing and Decapping

1. Problem: Case not properly sized.

Possible Cause:

- Sizing die not adjusted correctly.
- Press operating handle not cycled all the way down to stops.

2. Problem: Decapping pin not decapping.

Possible Cause:

- Decapping pin bent or broken.
- Die decapping stem improperly adjusted.
- Berdan primed case.

3. Problem: Bent or broken decapping pin.

Possible Cause:

- Berdan primed case.
- Flash hole not centered in case.
- An obstruction inside case.

4. Problem: Primers hang up in the ram primer ejector slot and do not discharge into the primer catcher.

Possible Cause: Improperly adjusted decapping stem.

Remedy: The decapping stem is set too deep. Loosen the decapping stem and raise the stem as needed. The decapping stem need only be set deep enough to eject the primer and no further.

5. Problem: Oil dents in case shoulder or wrinkled casenecks.

Possible Cause: Using too much case sizing lubricant.

Remedy: Reduce the amount of lubricant used and disassemble and clean die as needed.

6. Problem: Crushed Cases.

Possible Cause:

- Not enough radius on die mouth.
- Case not centered in shellholder upon entry into die.
- Attempting a case forming operation that is too radical to perform in one step.

Remedy: Guide cases into die. If reforming cases, use case forming dies.

7. Problem: Scratched or marked cases.

Possible Cause:

- Dirty brass.
- Scratched die.
- Brass or nickel adhering to carbide insert. Use a good bore solvent to dissolve these deposits.

8. Problem: Cases are hard to size and/or squeal during sizing.

Possible Cause:

- Not enough case lubricant used.
- Not enough time allowed for evaporation of carrier for spray type case lubricants.

9. Problem: Stuck case and torn case rims.

Possible Cause:

- Not enough case lubricant used.
- Not enough time allowed for evaporation of carrier for spray type case lubricants.

Remedy: If the case rim is intact, rotate the shellholder until it is oriented to allow removal from the press ram. Slide out the shellholder and unscrew the die. Use a stuck case puller to remove the case. If the case rim is torn off, unscrew the die and use a stuck case puller to remove the case. Remove torn rim from shellholder. Reinstall die and lubricate cases properly.

Case Mouth Belling

1. Problem: Over or under flared cases.

Possible Cause:

- Improper die adjustment.
- Variations in case length.

Bullet Seating

1. Problem: Top of bullet is deformed.

Possible Cause:

- Case not flared enough.
- Soft lead.
- Lead or wax buildup in die.
- Incorrect seating stem for bullet style used.

2. Problem: Shaving lead or lube.

Possible Cause

- Case not flared enough.
- Bullets are not correct diameter.
- Burrs on case mouth.

3. Problem: Loose bullets.

Possible Cause:

- Over crimping.

- Incorrect bullet diameter.
4. Problem: Inconsistent seating depth.
Possible Cause:
 - Variations in case and bullet dimensions.
 - Lead or lube buildup in die seating stem.
 - Incorrect seating stem for bullet style used.

Crimping

1. Problem: Cases are over or under crimped, or crimping is not consistent.
Possible Cause:
 - Over flared case.
 - Die not properly adjusted.
 - Variations in case length.
2. Problem: Loose bullets.
Possible Cause:
 - Over crimping.
 - Wrong expander.
 - Thin cases.

Limited Warranty

Every Frankford Arsenal product is warranted to be free of defects in materials and workmanship for a period of one (1) year from the date of original purchase. Frankford Arsenal will, at its option, repair or replace without charge, except for transportation costs, parts that fail under normal use and service when operated and maintained in accordance with our Instructions. This warranty does not apply to normal wear or to items whose life is dependent upon their use and care. This warranty is in lieu of all other warranties, expressed or implied and releases Frankford Arsenal, its affiliates, and its vendors from all other obligations and liabilities.

5885 W Van Horn Tavern Rd. • Columbia, MO 65203

Visit our web site at www.frankfordarsenal.com

A **B** **attenfeld** Product

Revised: 01-13-00