

BASIC RELOADING FOR HUNTERS

©Ivan Hardwick 1998

Table of Content

Section 1 – Introduction

Section 2 – Reloading Equipment

Section 3 – Components (Cases)

- Primers
- Bullets
- Powder

Section 4 – The Basic Reloading Process

1. Preliminaries
2. Case Preparation
3. Primer seating
4. Powder charging
5. Bullet seating
6. Final points

Section 5 – Load Development

- Bullet Energy Table

Section 6 – Reloading Safety

- Working Area
- Components
- Working Routine
- Cases
- Primers
- Storage
- Keep Alert
- Think Safety

Section 7 – Hand-held Reloading Tools

- The Lee Loader
- The Lyman 310 Reloading Tool
- Other Hand-held Tools

SECTION 1 - INTRODUCTION

There is a widespread lack of knowledge and misunderstanding about reloading among hunters, who view it with not a little suspicion. Before getting into the meat of the subject let us try to dispel some of these misconceptions.

Firstly - safety. Stories abound of accidents apparently caused by reloading or using reloaded ammunition. Reloading is a very safe activity provided you follow simple basic safety rules, which will be covered later. There have been accidents caused by using reloaded ammunition, usually through either overloading, or disregarding one of the other basic rules - it comes down to "pilot error" on the part of the reloader. Provided a rifle is in serviceable condition you are unlikely to have any problems, and reloaded ammunition can actually shoot more accurately and cause less wear and tear than factory ammunition.

Secondly - the fire risk. Provided you follow normal storage precautions you need not worry. There are many common household items that are far more dangerous, such as gas cylinders, gasoline, thinners and other solvents.

Next - reliability. There are hunters who use reloads to practice but hunt using factory ammunition! Again, provided you are careful, there is no more danger of a misfire or other failure caused by using reloaded ammunition. In fact by reloading you can choose to use "premium" components, especially bullets, which are not available commercially loaded.

Is it worth it? Some hunters feel that they shoot so little that the time and effort, let alone the expense of reloading are hardly justified. Certainly no gunshop proprietor will earn enough by selling ammunition to hunters to ensure a

comfortable retirement! The initial expense may seem high - to equip yourself for reloading can cost the same as buying 200 - 300 rounds of commercial ammunition - but that includes sufficient components to make your first 100 rounds. There is another side to this - if you buy ammunition once you have fired it you are left with a pile of empty cases - the single most expensive component! They are easily recycled and can be reused quite a number of times before worn out. As a rough guide it costs about the same to reload 50 rounds as to buy 15 rounds of factory ammunition.

Another benefit of reloading is that you can afford to practice - the expense of factory ammunition frequently discourages hunters from practising sufficiently, or even periodically checking zero - yet we owe it to our quarry to do everything we can to ensure a quick and humane kill. If you reload you can afford to practice and check zero often.

Modern commercial ammunition is reliable and usually shoots well in any rifle. At times it can be very good indeed, but it is made for the "universal rifle" - it is made to a common standard of dimensions and pressure levels, designed to cope with a variety of firearms of different ages and conditions. Every rifle is individual - just try chambering a case fired in one rifle in a couple of others. By reloading you can tailor the ammunition to *your* rifle.

In summary the three main justifications are: Cost, Quality and Versatility. By reloading you can save considerably (or shoot more for the same money), you can produce ammunition that should shoot as well as anything you can buy, if not better, and finally you can produce a much greater variety of ammunition than is commercially

available. You can tailor ammunition to your particular needs - you can develop a hard-hitting and flat-shooting load with a heavy bullet for use against moose or elk, and also work up a soft load for use against deer, giving superb accuracy with little noise or recoil and considerable reduction in meat damage over commercial ammunition.

By reloading you can match your ammunition to your rifle and tailor it to do the job you want it to do, you can improve your sport, get improved accuracy and increased versatility, reduce your costs and also enjoy a fascinating and worthwhile hobby.

SECTION 2 - RELOADING EQUIPMENT

Let us now consider the equipment you need to begin reloading. As well as the essential items there are also some pieces of equipment that help to make life easier and increase the quality, or the speed of production of your ammunition and some that you may like to consider getting at a later stage, when your knowledge and expertise have increased.

The first, and probably the single most important item on your list, absolutely essential for almost any reloading activity, is a reliable and accurate set of scales. You need a set that will weigh to 1/10 grain (about 437.5 grains = 1 ounce!) and there is really no alternative to buying a set purpose-made for reloading. They must be magnetically damped, otherwise you will find that you spend a lot of time waiting for them to come to rest.

Two bits of advice - first don't be tempted to cut costs or go for second-best and secondly, unless you are sure that a pair of second-hand scales have not been ill-treated, buy new. And look after them - a good set of scales will last you as long as you are likely to be reloading if properly cared for. Keep the original packing and carton and if taking them anywhere pack them up carefully. Should you ever drop them inspect them carefully and if possible check them to see if they are still accurate. Lyman make a set of check weights, which

are invaluable from time to time - perhaps a good investment for a group to buy.

Most scales weigh up to a maximum of 500 grains, which is adequate for almost every purpose. The inexpensive Lee scales only have a maximum capacity of 110 grains, which is fine if you are only weighing powder charges, but if you are likely to need to start weighing cases or bullets in your search for ultimate accuracy then it would be insufficient.

Next you need either a press and dies, or perhaps if your reloading needs are very limited, you could try a hand held tool like a Lee Loader. While the hand held tools can produce very good quality ammunition they restrict you to a slow rate of production and, because they only resize case necks, they are really only suitable for use with new cases or cases that have been fired in your rifle. I personally prefer to use a press and dies.

There is a large variety of presses to choose from and it can be confusing. Basically they can be divided into single-station, multi-station and semi- or fully progressive presses. The latter are, in the most sophisticated examples, small ammunition factories. My advice is not to consider them unless you are intending to shoot a lot - they are of most use to a competitive pistol shooter, needing several hundred rounds a week. They are

unsuitable for use by novices and I would advise you most strongly not to even consider them until you have considerable experience.

A multi-station press may take your fancy instead. They have the advantage that you can leave your dies set up permanently. They will enable you to save time, but are usually more expensive than a single station press. There are two basic types, the turret press, with a disc on top which is rotated to bring each separate die into use, and the H - type, with a separate shellholder under each die, necessitating a move of case from station to station. The thing to watch out for is that the press is robust enough to cope with the strain of full-length sizing of rifle case - opt for the strongest you can afford.

There are two basic forms of press frame, usually referred to as 'O' or 'C' frame. This refers to the shape - a 'C' frame is open sided, whereas the 'O' is closed (as in the letters of the alphabet). Some of the early 'C' presses had a reputation for flexing under pressure, but the modern ones are stronger.

With dies there is no particular recommendation. Most rifle cartridges require a two die set, the first decapping (removing the spent primer), resizing (reducing the expanded case to approximately its original dimensions) and expanding the neck to the correct size to accept a bullet: the second seats the bullet and, where necessary, crimps the neck.

There are a number of specialist dies on the market - the 'Benchrest' types have a very fine seating depth adjustment (sometimes with a micrometer) and an internal sleeve to align the bullet precisely with the case neck. These are really too specialised for hunters' needs. However a part way step is to consider the Hornady 'New Dimension' dies, which have a special straight - line seater, as well as a

different-shaped expander. You may also care, at a later date to think about a neck-sizing die, but at this stage it is best to full-length resize your cases.

After you have resized a case it is worth cleaning out the primer pocket. Here you have the choice of either a hand tool or an attachment fitted to your case trimmer.

Some form of case trimmer is a vital part of your kit. The simplest is the Lee tool, which consists of a shellholder, into which the head of the case is locked, and a cutter, into which is screwed a length gauge for the particular calibre. It is inserted into the case mouth until the end of the gauge fits through the flash hole. It is then rotated and removes excess brass until it butts against the lock stud. It can even be used with an electric drill to speed things up. However it will only trim a case to a standard length, whereas the more expensive tools are adjustable, and you need to buy a shellholder and length gauge for each different calibre.

The other type of tool is bench mounted and best described as a small hand operated lathe. You set it for length, lock a case into it, and crank away at the handle. The choice is wide, with most manufacturers offering at least one, each with their own individual points, and some with a number of accessories. Some tools can also be used for neck turning and reaming - not normally needed for reloading for hunting, unless you are going to be modifying cases (forming .243 cases from .308 for example).

Whatever method you use you will need to use a deburring tool afterwards to get rid of the small metal burr left after trimming and cut a chamfer on the inside of the case mouth, to ensure the bullet is not damaged when being seated.

An optional but very useful item is a case polisher - these consist of a rotating or vibrating drum into which a number of cases are placed, with a polishing medium. It is then a case of switch it on and go away - after a couple of hours they will be nice and shiny - but also spotlessly clean, inside and out.

If your press or reloading kit does not include a priming tool then that is the next item you will need. Here you have a choice between a tool which mounts on your press or a separate, usually hand held item. The simple little Lee Auto-Prime is very popular - it is quick and easy to use and sensitive enough to allow you to 'feel' the primer seating.

A word of warning - **IT IS ABSOLUTELY IMPERATIVE THAT YOU WEAR SAFETY GLASSES AT ALL TIMES WHEN HANDLING PRIMERS**, whatever priming system you use. There have been instances of primers being set off during reloading, and it is not worth taking any risks with your eyesight.

Handling cases is much easier if you have some sort of loading block to stand them up in - you can make one from a piece of scrap wood using a drill, but the commercial ones are much easier. It save accidents knocking over cases full of powder and enables you to organise your work space better.

You will need to lubricate cases before resizing them and for this you need a lube pad and the proper lubricant. It is also best to lubricate the inside of the neck either using a case neck brush or a neck dipper, which uses a dry powder lubricant.

A powder funnel is another item you really need - it has a reverse taper at the bottom of the neck so that it will fit happily onto the top of any case.

When it comes to measuring the powder charge, life can be made easier with a bit of mechanisation. The simplest (and very time consuming) method is to use a teaspoon to drop powder into the scale pan, but this is horribly slow. Better to use a powder trickler, which trickles a small stream of powder into the pan until you reach the required weight - there is even an electric version which is very time saving.

The best method is to dump an approximate charge, then top-up using a trickler. You can measure your charge, with a scoop, either home made from a fired case and a bit of wire or from a kit such as the Lee Powder Measure Kit, or you could use an adjustable measure.

Once you have mastered the use of an adjustable measure, and provided you are using a suitable powder (i.e. relatively fine grained), you can throw powder charges directly from the measure. However you need to check frequently to ensure that you are not over or under charging - at least every tenth charge.

A vernier caliper, or some other precision measuring tool, is not the luxury it may first seem. You can use it to check the length of prepared cases before reloading and the loaded round afterwards. You may, from time to time, need to check other measurements, such as the diameter of bullets or case necks. Whatever you get needs to be accurate to 0.001", as small changes in dimensions when reloading can have grave repercussions!

There is also a useful tool made by Forster, a combination case length and headspace gauge, a tube machined to hold a resized case with a machined step at each end - the ends of the case must be between the maximum and minimum dimensions.

To cope with the almost inevitable requirement to dismantle ammunition a bullet puller is useful. There are two types: kinetic or press mounted. The former looks like a hammer, with a collet to grip the case head. You insert a loaded round, lock it tight, then strike the tool smartly on a hard surface - after a couple of taps the bullet should be drawn and you can remove the case and pour out the bullet and powder. The case can then be reloaded without any need to deprime or resize.

Two points to watch - first wear your safety glasses and secondly NEVER USE A KINETIC PULLER WITH BERDAN PRIMED AMMUNITION because of the way the primer sits against the fixed anvil there is a possibility that it could be detonated.

A press mounted tool however can be used quite safely. It consists of a body, similar to a reloading die, that is inserted in

the press. You drop in a suitable size collet and tighten it down to grip the bullet, then by pushing up on the press handle the bullet is withdrawn from the case. It has the advantage also of being rather quieter, but there is a possibility that the bullet may be marked or the rim of the case torn. I have both tools and use them about equally, but to begin with you need only one.

Finally you need some suitable containers to store your ammunition. The original factory boxes are not very robust and you would do well to get some hard wearing plastic boxes. Store ammunition in 100 or 50 round boxes and carry it in the field in 20 or 10 round containers.

That then is a brief run through equipment. Below is a list of reloading gear divided into essential basic items and optional 'nice to have' extras.

Basic Reloading Kit	Optional Items
Safety glasses	Vernier caliper
Scales	Case length/headspace gauge
Press, dies & shellholder (or hand tool)	Case polisher
Priming tool (if not in press kit)	Auto-prime tool & shellholder
Lube pad & case lube	Powder trickler
Case neck brush/dipper	Powder measure
Case trimmer	Bullet puller
Deburring tool	Case tuner/Neck reamer (if forming cases)
Primer pocket cleaner	Scale check weights
Loading block	
Powder funnel	
Ammo boxes	

SECTION 3 - COMPONENTS

Cases

The main function of the brass case is to seal off the breech at the time of firing, by expanding to fit the chamber walls. It also needs to withstand the chamber pressure built up during firing. It therefore needs a structural strength of its own plus the additional support of the breech face and chamber walls. A rifle is no stronger than the case used in it. Cases are made from a special brass and are tempered during manufacture to ensure that the head is strong and rigid, while the walls, shoulder and neck are soft and ductile, so that they will expand readily.

Most rifle cases are 'bottleneck' shape, with the neck of rather less diameter

than the body. There are five different styles of head: Rimmed, Semi-Rimmed, Rimless (the most common), Belted (nowadays used mainly for magnums), and Rebated (only used currently for the .284 Winchester).

Cases are marked with a headstamp by the manufacturer and a golden rule is never mix cases of a different headstamp, there can be considerable differences in their weight, and therefore capacity, as well as differences in hardness. Also cases 'work harden' with use and will eventually split, usually at the neck. Cases are also made to be used with 'Boxer' or 'Berdan' primers - they are not interchangeable.

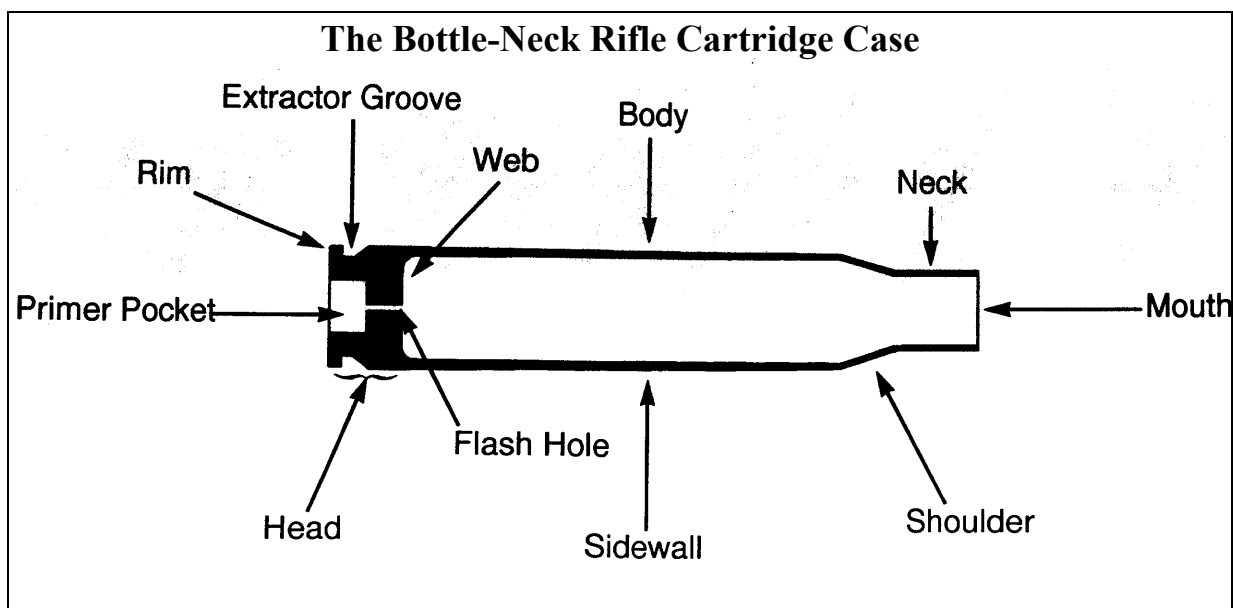
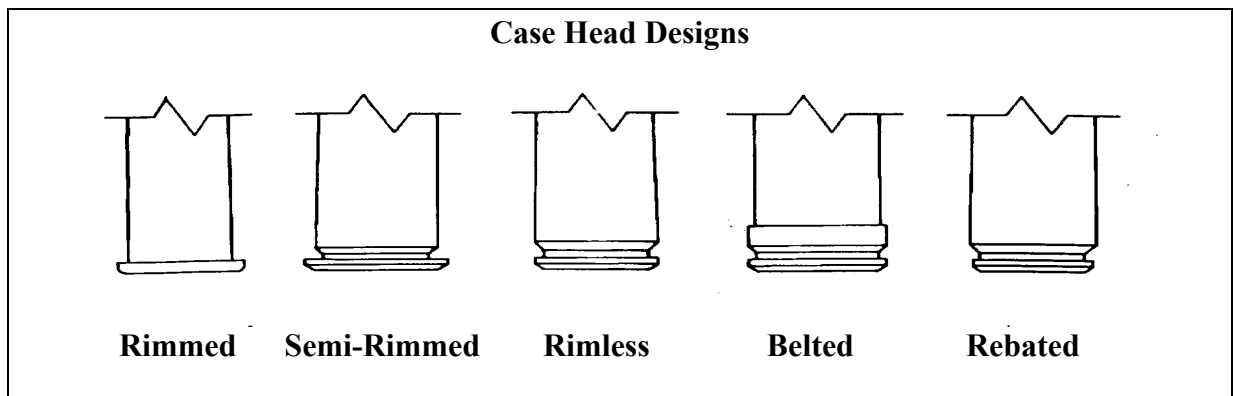

Primers

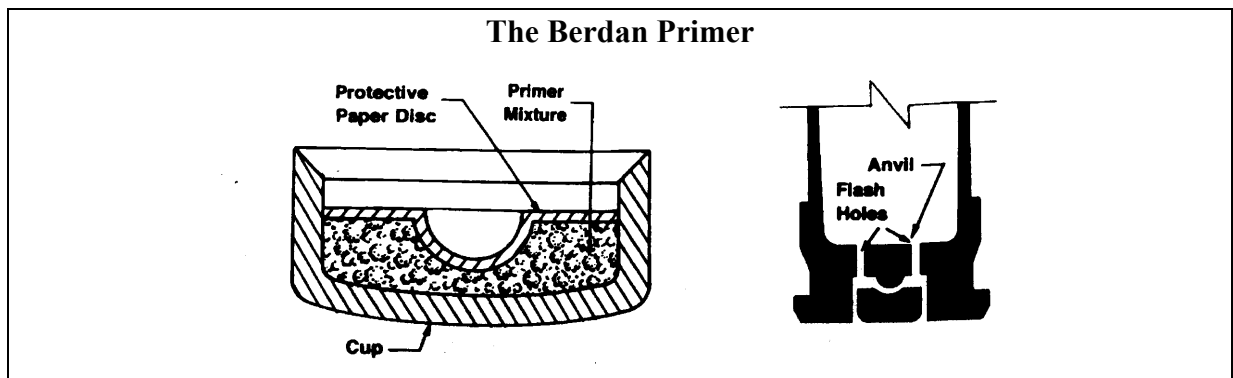
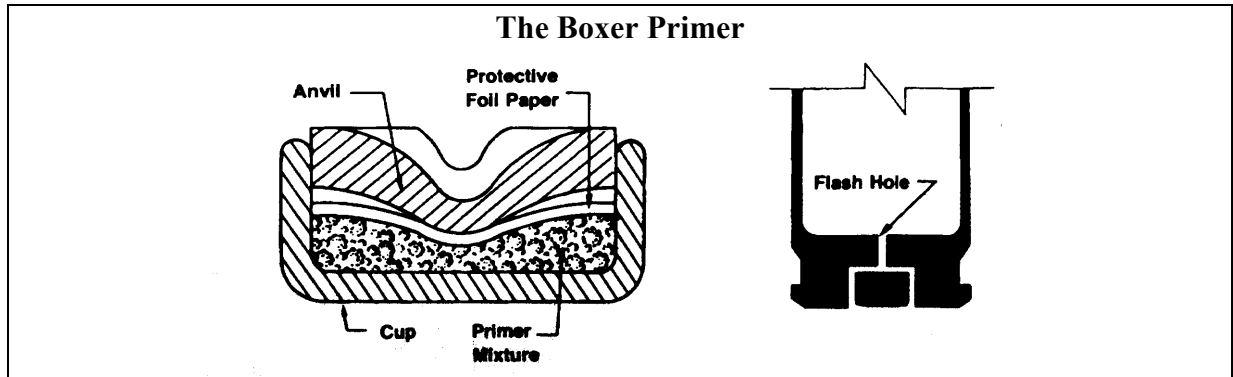

There are two different types of primer, named after their inventors. **Boxer** primers were invented by an Englishman and are the most common in use today. They have a separate anvil and if you look carefully you will see that it stands slightly proud of the primer cup. When the primer is correctly seated the anvil must be in close contact with the bottom of the primer pocket if it is to ignite correctly. However it must not be crushed, as then it may well misfire. It needs a practised touch, but you can actually feel the primer bottoming in the case.

Berdan primers originated in the USA, but are now found mainly in European cases and most military ones. The anvil is part of the case. The easiest way to tell the difference is to look inside the case - if it has two small, offset flash holes it is berdan primed. Working with berdan primers requires special tools to

decap cases and they are more difficult to seat. The best advice is to avoid them!

Primers come in two sizes, large and small. Most of the cases used for common hunting calibres use the large ones. They also come in two types, rifle and pistol. They are NOT interchangeable and you must NEVER use pistol primers in rifle cases - they are not made to take the same pressures.

The burning characteristics (brisance) of a primer can be critical. You will find Standard, Magnum and Match or Benchrest primers - again they are not interchangeable. The 'hotter' the primer the higher the temperature and pressure that will be reached. Certain powders, particularly the slower-burning ones and some spherical powders will not ignite properly or burn consistently unless magnum primers are used (they burn hotter and longer). Match or Benchrest primers

are made especially to provide the utmost consistency (and may burn hotter as well).

When reloading, a change of primer can have considerable effect on the pressure generated. If a load is developed

with one primer stick to it - standard primers from different manufacturers have very different characteristics - don't switch.

Bullets

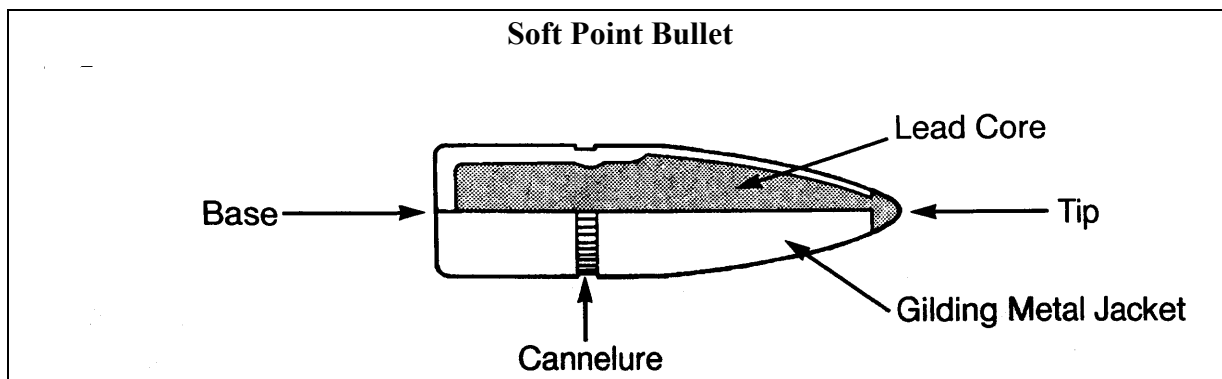

For hunting we need a bullet which will achieve a rapid and humane kill, and indeed we are required by law to use an expanding bullet. Our bullet needs to penetrate into the body cavity and expand rapidly, expending a large part of its kinetic energy and killing through the effect of shock. When you think about it we expect a lot from our bullets, for the target can vary greatly - a classic broadside heart/lung shot on a small deer may pass right through the animal without touching bone, whereas the same bullet on an elk may be required to smash through a shoulder in order to reach vital organs. If, in the first case the bullet passed through without expanding, or in the second, it blew up on impact with the bone you would probably fail to achieve a clean kill.

As you know spin is imparted to a bullet to stabilise it in flight through the air. The body of your target is largely composed of water, and as the spin rate of the bullet is insufficient to stabilise it in this denser medium it will begin to tumble. This on its own would be insufficient to ensure a clean kill, so the bullet is also

designed to expand. A bullet begins life as a 'cup made of gilding metal, an alloy of 95% copper and 5% zinc, into which is inserted a 'slug' of lead or lead/antimony alloy. In a military bullet the jacket is wrapped over the nose of the bullet, leaving a small area of exposed lead at the base, while a hunting bullet has the jacket wrapped over the base, leaving a small cavity in the nose or a small exposed lead point (thus making a hollow-point or soft-point bullet). Some bullets are given a streamlined base, known as a 'boat tail'. These are intended for long range shooting, as they are more aerodynamically efficient, but over practical hunting ranges the difference is very small.

The expansion of the bullet will depend on the thickness and hardness of the jacket, the hardness of the lead core and the velocity with which it is propelled. Normally the lighter bullets in any calibre are designed for small game or 'varmints' and have a thin jacket, sometimes with internal cuts or groove and a soft lead core, to guarantee very rapid expansion as soon as it hits its target. They can be propelled at high velocity and can have a spectacular

effect on rabbits – there is nothing left

worth eating though!

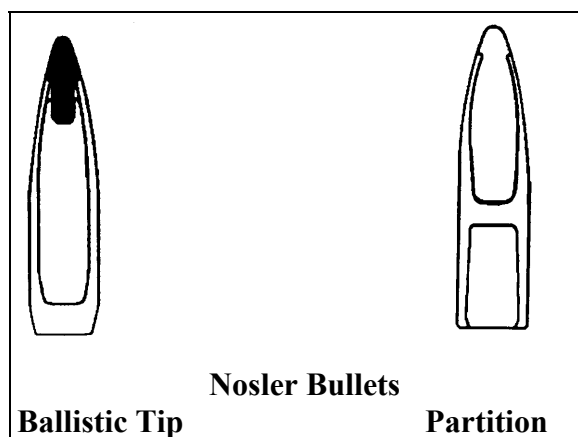
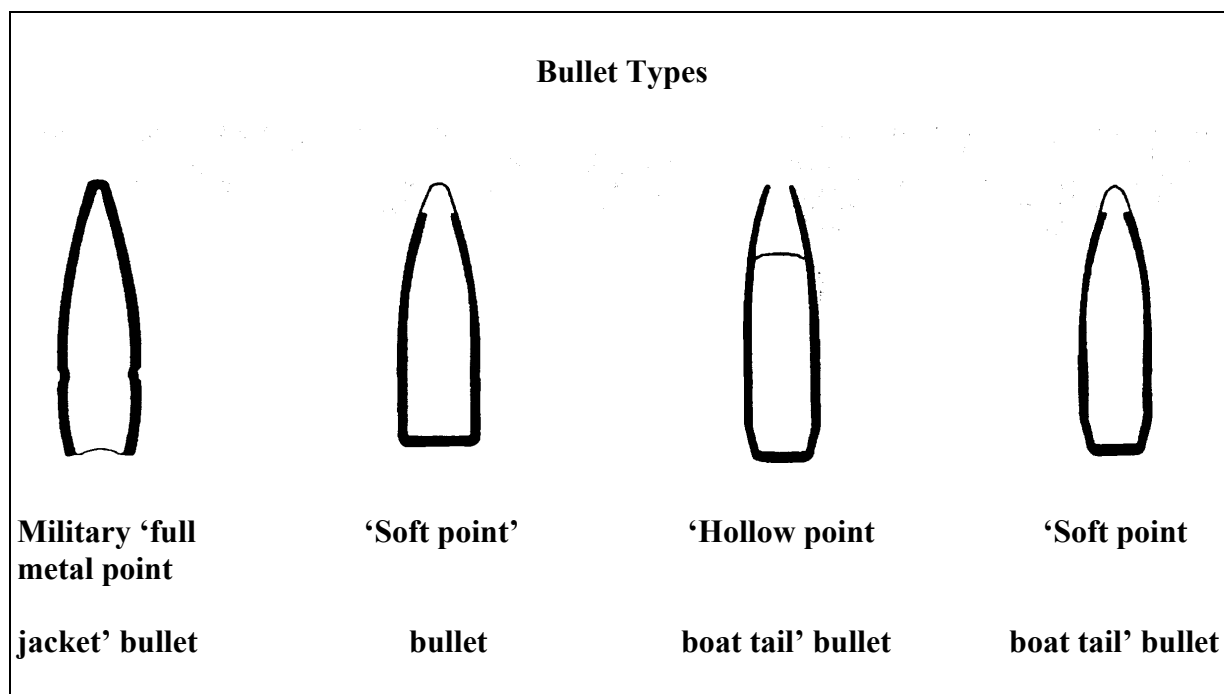

The same bullets used on deer will cause a massive surface wound, yet will fail to kill cleanly.

Bullet choice needs to be matched to the calibre of rifle. In the .243 the minimum weight bullet for effective use on deer is about 85 grains - and some of these may fail to penetrate a carcass. The damage to internal organs is comprehensive, yet the meat suffers little - but note that it can be difficult to find your beast, as very little blood trail is left if the animal runs after being hit. However the

same bullet propelled at higher velocity, for example out of a .240 Weatherby Magnum will expand much more rapidly and cause a lot more meat damage. Thus bullet weight must also be balanced against velocity. If you regularly shoot larger deer with a .243 I would recommend using a 95 or 100 grain bullet.

In a .308 the minimum weight for deer is 125 grain, and these can be very effective, although they need to be loaded to rather less than the maximum velocity to keep damage down - any lighter bullet, such as the 110 grain hollow point can be devastating. There have been cases where fragments of bullet jacket were found in the haunch of a deer that was shot in the neck with one of these. 150 grain is probably a better all round choice.

Similarly with the .270 the 110 grain bullet can be very effective on deer, although again it works best if handloaded to a reduced velocity. For all round use 130 grain is probably better.

There are some special and rather expensive bullets on the market. The Nosler Ballistic Tip is a hollow point with a small plastic plug inserted to give it a more streamlined shape. It is really intended for long range shooting and tends to expand very rapidly at close ranges so you need to be careful using them at high velocities. There are others, such as the Nosler Partition, Barnes X, Swift A Frame, to mention just a few, which are designed to give both penetration and controlled expansion, either by combining different lead alloys in the core or having a divider between the front and rear portions of the bullet. Recently Barnes in the USA have developed an all-copper 'X-Bullet'. All these are designed more for use on larger game, but they may be very effective for normal deer hunting.

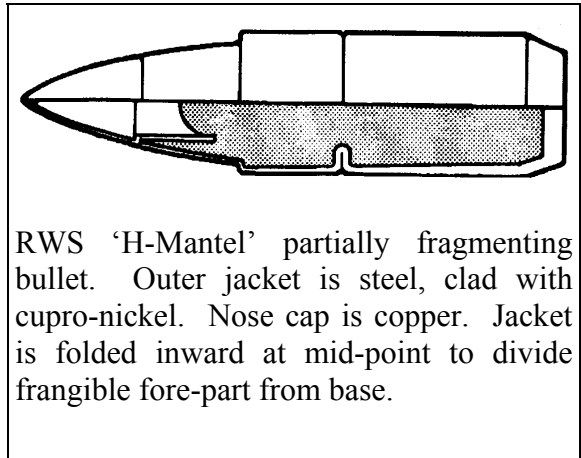

RWS 'H-Mantel' partially fragmenting bullet. Outer jacket is steel, clad with cupro-nickel. Nose cap is copper. Jacket is folded inward at mid-point to divide frangible fore-part from base.

Powder

'What powder should I use and how much of it?' is the most common query from reloaders - yet it is probably the most difficult to answer. In this country we are fortunate to have a very wide choice of smokeless powders, from the USA, Europe and Scandinavia. However there is a danger of being spoilt for choice.

The first smokeless powders were developed in about 1880 and were based on nitro-cellulose, produced by the reaction of nitric and sulphuric acids on cellulose fibres. Nowadays the process is further refined by using alcohol and ether as solvents, producing a gelatinous colloid, which is then rolled into sheets or extruded into a 'string' and finally cut and dried. Nitro-cellulose powders are usually referred to as 'single-based'. Double based powders were discovered in 1887 and differ by the addition of nitro-glycerine to the colloid. There are further additives and

coatings to control the burning rate and to make the powder flow more easily through a measure, although burning rate is largely controlled by the size and shape of the powder granules. More recently spherical powders have been developed, which have the advantage of being comparatively dense, thus enabling a heavier charge to be loaded into a small capacity case.

Double based powders tend to burn hotter and develop more energy, but can also leave rather more residue. They can also be more abrasive, but this makes little difference as far as our purposes are concerned, with the relatively small number of rounds fired, compared with, for example, a target rifleman.

Modern rifle powders burn relatively slowly at atmospheric pressures and require a minimum pressure of about 15 tons per square inch (tpsi) to perform efficiently. The maximum pressure for

which most hunting rifles are tested is probably in the region of 19-20 tpsi, depending on the calibre, so the pressure of a reloaded round must be kept within fairly narrow limits. The pressure developed when a round is fired can also have a great effect on the burning characteristics of the powder. The use of the same powder in a small-bore and large-bore cartridge can also produce very different results.

As a general rule the larger the bore the faster burning the powder you should use, but the capacity of the case and the bullet weight also come into it. The smaller the case capacity and the lighter the bullet the faster the powder burning rate should be for optimum results. For example while the .308 Win and .300 Win Mag may have the same bore size the latter gives the best with slower-burning powders, even with the same bullet. A glance at a reloading manual will help to give you some idea of the approximate area in the list below where you should find the best powders for your particular purpose.

In simple terms the best results are likely to be found with a powder that has a high loading density in the case you are using, yet still gives safe pressures and suitable velocities. It may help to look for the powders which give the highest velocities with the particular bullet weight you are planning to use, in other words the most efficient, unless you are seeking to achieve less than maximum velocity, if you are using lightweight bullets for example.

Some manuals show the most accurate loads found in their tests, but that applies to the test rifle and components used. There is no guarantee that the load concerned will prove the best in your rifle, although it does at least give an indication of a suitable powder. In the end there is no alternative to trial and error. It is possible to find two rifles of the same make and calibre which perform totally differently -

one giving the best results when loaded with a fast powder, the other with a slow one. There is no single "magic" recipe which will guarantee good results with any rifle.

While the dangers of over-heavy powder charges are obvious there are also dangers attached to under-charging, especially with slower-burning powders. There are a number of theories to explain the occurrence, but the key would seem to be the amount of air space remaining after the bullet is seated (referred to as the "loading density"). There are well-documented cases of reloaders who, having worked up a safe, if somewhat heavy load, in a large-capacity rifle case, decided for some reason to reduce the powder charge considerably, to discover that at best there were signs of abnormally high pressures, and at worst the rifle blew up! So if a manual recommends a minimum load go below it at your peril (this applies particularly with spherical powders). There are several tables available that give relative burning rates of powders, although opinions differ from table to table - I find them useful, as a *general* guide when looking for an alternative to a particular powder that is not available.

But please note - just because two powders are shown as having similar burning rates or, in the case of Hodgdon and IMR powders, have the same number (e.g. H4895/IMR4895) does not mean that the same load data can be used - to do so is to invite trouble. Similarly the performance of one batch of powder relative to another can vary and it is wise to make up a few trial rounds just to check when using a new batch of powder, especially if you are in the habit of using maximum loads.

Burning Rate Chart

Canister grade powders in order to approximate burning rate
(This list is approximate only and should not be used for developing loads)
 (Based on an original article in *Gun World* magazine)

1	Norma R-1	48	Norma N-200
2	Vihtavuori N310	49	Vihtavuori N133
3	Hercules Bullseye	50	Brigadier 4197
4	Solo 100	51	Hodgdon H-4198
5	Accurate Arms No.2	52	IMR-4198
6	Hercules Red Dot	53	Hercules Reloder 7
7	Vihtavuori N320	54	IMR-3031
8	Royal Scot D	55	Norma N-201
9	Hodgdon HP-38	56	Hodgdon H-322
10	Win 231	57	Accurate Arms 2230
11	Hodgdon Trap-100	58	Brigadier 3032
12	Scot 453	59	Win 748
13	IMRHi-Skor 700-X	60	Hodgdon BL-C(2)
14	Win 452AA	61	Accurate Arms 2460
15	Hercules Green Dot	62	Hodgdon H-335
16	Vihtavuori N330	63	Hodgdon H-4895
17	IMR PB	64	Hercules Reloder 12
18	Accurate Arms No 5	65	IMR-4895
19	Hercules Unique	66	Vihtavuori N135
20	IMR SR-7625	67	IMR-4064
21	Win 473AA	68	Brigadier 4065
22	Hodgdon HS-6	69	Accurate Arms 2520
23	Vihtavuori N340	70	IMR-4320
24	Win 540	71	Norma N-202
25	Hercules Herco	72	Vihtavuori N140
26	IMR SR-4756	73	Hercules Reloder 15
27	Solo 1250	74	Hodgdon H-380
28	Vihtavuori 3N37	75	Win 760
29	IMR Hi-Skor 800-X	76	Vihtavuori N150
30	Accurate Arms No 7	77	Hodgdon H-414
31	Solo 1500	78	IMR-4350
32	Vihtavuori N350	79	Hodgdon H-4350
33	Hodgdon HS-7	80	Norma N-204
34	Hercules Blue Dot	81	Brigadier 4351
35	Accurate Arms No 9	82	Hercules Reloder 19
36	Hercules 2400	83	Vihtavuori N160
37	Vihtavuori N110	84	IMR-4831
38	Norma R-123	85	Accurate Arms 3100
39	Hodgdon H-110	86	Hodgdon H-450
40	Win 296	87	Hodgdon H-4831
41	IMR SR-4759	88	Norma MRP
42	Vihtavuori N120	89	Vihtavuori N165
43	Accurate Arms 5744	90	Hercules Reloder 22
44	IMR-4227	91	IMR-7828
45	Hodgdon H-4227	92	Hodgdon H-1000
46	Accurate Arms 1680	93	Accurate Arms 8700
47	Win 680	94	Hodgdon H-870

SECTION 4 - THE BASIC RELOADING PROCESS

(Using a press and standard dies)

When a round is fired the case expands to fit tightly in the chamber of the rifle then, once the chamber pressure drops the elasticity of the brass case causes it to contract slightly so that it can be extracted. It is however a close fit in the chamber and to function properly, and especially if it is to be reused in a different rifle it will almost certainly need to be brought back to something approaching original dimensions, a process known as 'full-length resizing'. To do this it is inserted into a precision machined die which forces it back into shape, at the same time removing the spent primer. As a case is extracted from the die the neck, which has been reduced to less than the diameter of the bullet, it is expanded by a small button on the decapping rod, to bring it to fractionally less than the bullet diameter, so that it will grip the bullet tightly when it is seated in the neck.

A fresh primer is inserted and the case filled with a measured charge of powder, then a new bullet is inserted in the neck and seated to the correct depth. However, simple as it may be in theory, there are many traps for the unwary along the way.

The process is best divided into six easy stages: Preliminaries, Case preparation, Primer seating, Powder charging, Bullet seating and Final points.

1. Preliminaries

Assemble all the tools and materials you will need - and ensure you have everything. There is nothing worse than getting part way through to find that you are short of a vital item. Lay everything out tidily on the bench and do everything you can to ensure a lack of

distractions and interruptions. It is not only frustrating, but also potentially dangerous to break off in the middle of reloading a batch of ammunition to find, when you return, that you have forgotten what stage you had reached. Try to lay out the bench so that everything is positioned to ensure a logical sequence. Work out a system that suits you and position the equipment so that you follow the same pattern and the routine becomes almost automatic. Clear the bench of anything not required - you do not want to risk a mix-up with powder or other components - and finally double check everything.

2. Case Preparation

This is time consuming but very necessary and it can be the key to accurate and consistent results with reloads. First inspect your cases thoroughly, ensuring they are all of the same make (if using new ones try to ensure they are all from the same lot). Case capacity can vary tremendously and the effect of this variation on your results can be enormous - what is a perfectly safe load in one case can cause dangerous pressure levels in others.

Check by looking inside the case that they are boxer primed and examine carefully for any signs of damage: splits, deformation, discoloration or decay. If in doubt - chuck it out - and crush it using pliers to make sure it is never used again. Inspection is always easier if the cases are clean so it pays at the very least to give them a good wipe with a cloth soaked in a suitable solvent (or use a case polisher). Even new cases may not be undamaged - particularly around the mouth, so you should always partially resize brand new cases. Place your cases in a loading block,

all the same way up (the reason for this will become clear). If you have large dents in the mouth try to ease them out gently, without deforming the case.

The next stage is to set UP your resizing/decapping die. You should have dismantled, cleaned and reassembled it. Make sure that the thick portion of the decapping rod is not protruding otherwise it could be damaged. Insert the shellholder into the press and lower the handle so that the press is closed. Now loosen the lock nut and screw the die down into the press until it makes contact with the shellholder. Raise the press handle and screw the die down another quarter of a turn - this will ensure that all the slack is taken up when the pressure needed to resize the case is applied. Tighten up the lock nut and lock it into place. Take your case lube pad, smear a little lubricant across the surface and spread it with your finger. Roll the case neck brush across the pad so that it picks up a trace of lubricant. Lay about five cases on the pad and roll them across the surface until they have a thin coating of lubricant on the body of the case. Try not to get any on the shoulders, or more than a very slight smear on the neck or it may be damaged. Use the case neck brush to clean and lubricate the inside of the case neck (or use a case neck dipper) and then place a case in the press, making sure that it is located properly in the shellholder.

Lower the press handle - you should feel some resistance but no undue force should be needed. If it seems to offer a lot of resistance push the handle back up, withdraw the case and check that it is properly lubricated. A dry case can lock up solid in the die and take a lot of trouble to remove, probably needing the services

of a friendly gunsmith (if you use RCBS dies the importers, Edgar Brothers, offer a removal service for stuck cases).

As the press handle reaches the top of the stroke you may hear a slight pop - this is the old primer being removed (do you have a container to catch it)? Now raise the handle - you should feel a slight resistance as the neck expander does its job and then you will be able to remove the resized case. Check that the old primer has been removed and the neck has been properly resized - to the junction of the shoulder and neck. If you have a Forster Combination Gauge you can easily check you have not overdone the resizing (although this is unlikely if the die and shellholder are made by the same company).

Place the resized case in the loading block the other way up, and continue the process with the next case. By turning the cases over after every operation you will always know the stage you are at and are unlikely to fail to miss out one or work on it twice.

Wipe the case clean of every trace of lubricant (you can use the case polisher to ensure total removal) and clean the primer pocket. Next they will need to be trimmed to a uniform length - either by using a properly set case trimmer or, and by far the easier and cheaper way, by using a Lee trimming tool, which can be used with an electric drill. Trimming will leave a small burr on the inside and outside of the case mouth, which will need to be removed using a deburring tool, also leaving a slight chamfer on the inside of the mouth, to ensure the bullet will not be damaged during seating.

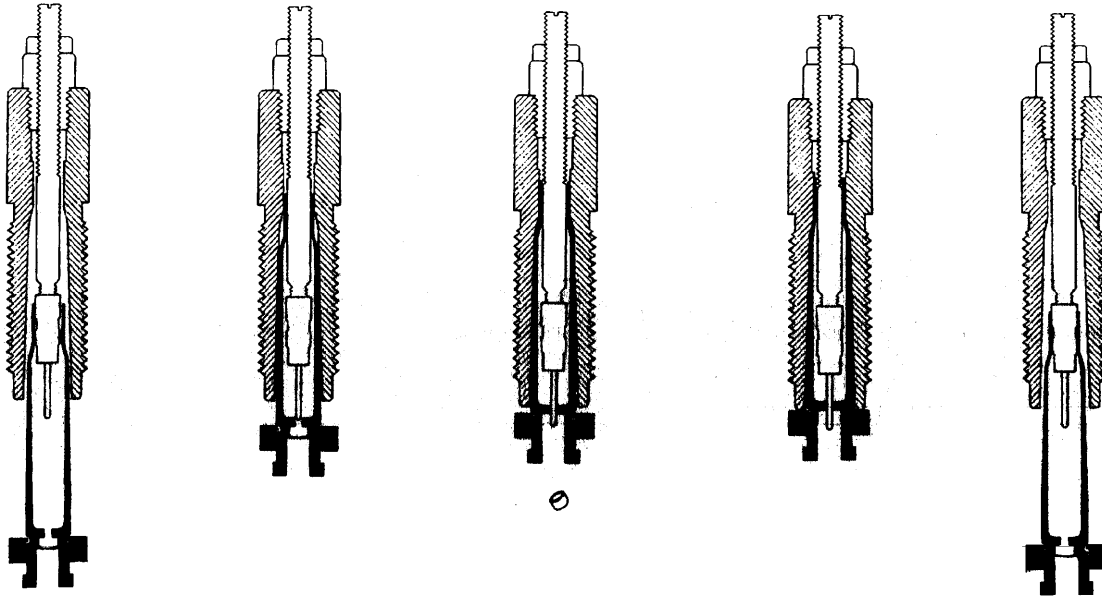

Full Length Resizing

- As the ram is raised, the expander ball guides the case into the die
- Near the top of the stroke, the case makes contact with the sides of the die chamber.
- The case is partially resized. The shoulder has not made contact with the die and is left as fire-formed. The depriming pin ejects the spent primer.
- At the limit of the stroke, the case, including the shoulder, is in full contact with the die and has been returned to original dimensions.
- On the down stroke, the case is withdrawn and the expander ball is drawn through the case neck, sizing it to friction-grip a new bullet.

3. Primer Seating

The actual process used will depend on your chosen priming system. The vital thing is SAFETY - always wear safety glasses when handling or working with primers. Check to ensure your primers are correctly seated (just below the case head) and undamaged. If you begin priming with cases head up in the loading block, you can place them mouth up when they are primed ready for the next stage.

4. Powder Charging

Powder charges can either be individually weighed or thrown using a measure. If weighing charges individually

the easiest method is to dump an approximate load into the scale pan then top up with a powder trickler or by dropping a granule at a time from a scoop - life is easier with a trickler. An alternative, and quicker way is to use an adjustable measure. These can take a little time to set up but with practise you can throw a charge to within 1/20 grain with most powders. However you should check frequently that the charge weight is still correct - at least every tenth charge. The secret is to operate the measure in a consistent fashion. Some powders, especially the 'long grain' ones can be very awkward to measure tending to 'bridge' in

the neck and block it whereas the finer ones, and especially the spherical powders, can be thrown with remarkable consistency.

Once you have charged all your cases make a quick visual check, just to make sure the level looks the same in each case - if in doubt check any that look suspicious. With most rifle cases and powders there should be little danger of double charging.

5. Bullet Seating

The steps to follow will be different depending on whether the case neck is to be crimped or not - you can only crimp the case if the bullet has a groove or 'cannelure' into which the case mouth can be crimped. The purpose of crimping is to ensure that the bullet is held firmly in the neck. This is usually only necessary with powerful magnum rifles or rifles with tubular magazines, in which rounds sit nose to tail.

If not crimping set up the die as follows: having cleaned it place it in the press and lower the handle with an empty case in the shellholder. Wind the die down until you can feel it make contact with the neck of the case, then back it off about 1/2 turn and lock it into place with the lock nut. Place a bullet into the case mouth and work the press so that the bullet is partially seated. Adjust the seating punch a little at a time until you reach the required seating depth and then lock it tight. I make a habit of keeping a specimen of each round that I reload so that I can adjust the die quickly and easily.

In setting up the die to crimp the case follow the same process: wind the die down to contact the case neck - back it off 1/2 turn - seat the bullet to the cannelure, then wind the seating punch back a couple of turns. Now loosen the lock nut and wind the die down until it touches the case neck. Raise the handle, wind the die down 1/4 turn and cycle the press. The case neck should now show a slight crimp. Continue this process until you have the required crimp then set the lock nut. Now, leaving the case with the crimped bullet in the press wind down the seating punch until it makes firm contact with the bullet and lock it in place. You have now set up the die to seat and crimp in one operation. Rifle ammunition seldom needs crimping - it is much more common with pistol ammunition.

6. Final Points

When you have finished reloading your batch of ammunition there are a few final steps. First make a record of your load - the length, make of case, primer and bullet make, bullet weight, powder charge and batch number, date loaded and any other relevant information. This will help when you want to reload a repeat batch. It is also advisable to check the width of the neck on a few rounds to make sure that they are within limits. Finally, outdoors and very carefully, load each round into the rifle and cycle it through the action - this is an insurance against the fateful day when you need to get off that quick second shot and find the round will not chamber when you work the bolt.

That then is the basic reloading process, with some of the more usual pitfalls highlighted.

SECTION 5 - LOAD DEVELOPMENT

The correct use of reloading data tables is probably the most crucial of the many steps in the handloading process, and yet it is frequently misunderstood, or worse, overlooked, by many home loaders.

The major manufacturers of components and equipment publish 'recipes' for a very wide range of calibres and bullets. These can range from the very simple, which give only the basics: calibre, bullet weight, powder used and charge weight; to the very detailed, which list not only all the above, but also include the make of case, primer and bullet, the overall length of the loaded round, chamber pressure, obtained velocity and sometimes other information as well. Remember, however, that whatever the data supplied it is at best only a guide.

It is extremely important that you do not just copy the listed recipe and apply it directly to your rifle: load component combination. Even if all your components match those in the data exactly, every rifle, even two that are apparently identical, will produce differing pressures and ballistics with the same load.

The range of components available in this country is extensive. Most come from the USA, with a small amount coming from Europe. The selection is adequate to cover most of the needs of reloading hunters. The first consideration in choosing what manuals will best serve your needs therefore, is availability of components. As far as powders are concerned Alliant, Hodgdon, IMR, and Winchester (USA) and Vihtavuori (Finland) are readily available at present. You may come across RWS (Germany), but a regular supply cannot be relied on. Norma (Sweden) is no longer available,

but some powders made by Norma are now marketed by Alliant under their own name. Nobel (UK) is only available commercially in bulk (although they make a lot of powders that are used by Hodgdon - they are shipped to the USA, and packaged).

We are better served with bullets; Nosler, Hornady, Sierra and Speer (all USA) are readily available, RWS (Germany) occasionally, and Norma (Sweden) seldom. Primers come from CCI, Remington, Winchester and RWS (Germany).

Several makes of cases can be found with a little effort. Remember that no components are totally interchangeable - once you have your load developed it is advisable to stock up with the components.

Most of you will already have your rifle, so for the most part the choice of what calibre to reload will not be in question.

Finally we have to address the question of what we want this ammunition to do for us - and what the law requires it to achieve in ballistic terms. Hunting ethics require sufficient muzzle energy for a clean kill, so our load must match, or better still, exceed this. To determine the muzzle energy of a particular load we must first know the muzzle velocity. This can be measured with a chronograph, once we have produced the ammunition, but in the first instance we can use published velocities as a guide.

However do remember the effect of differing barrel length - in general terms the longer the barrel the higher the muzzle velocity will be with the same load. Most factory test barrels are 24", sometimes

even 26” and the figures in a manual will normally show this.

Muzzle velocity can differ by as much as 300 feet per second (fps) when the same load is fired from a 24” barrel compared with an 18” barrel. As a general guide the following figures can be used:

<i>Muzzle Velocity Range (fps)</i>	<i>Approximate change in MV per 1” difference in barrel length</i>
2000-2500 fps	10
2500-3000 fps	20
3000-3500 fps	30

(Note: This is only a guide. To be certain you would still need to use a chronograph to establish the true velocity of your reloaded ammunition.)

To determine muzzle energy the following equation is used:

$$\frac{\text{Velocity}^2}{2} \times \text{Bullet Weight} = \text{Energy}$$

450240

(Velocity in feet per second, bullet weight in grains, energy in foot pounds.)

It is however easier to use a chart, such as the one at the end of this section.

To recap on powder choice, in simple terms the best results are, in theory, likely to be found with a powder that has a high loading density in the case you are using, yet still gives safe pressures and suitable velocities. It may help to look for the powders which give the highest velocities with the particular bullet weight you are planning to use; in other words the most efficient, unless you are seeking to achieve less than maximum velocity, if for example using lightweight bullets.

Some manuals show the most accurate loads found in their tests, but you should remember that applies to the test rifle and components used. There is no guarantee that the load concerned will prove the best in your rifle, although it does at least give an indication of a suitable powder. In the end there is no alternative to trial and error. I have known two rifles of the same make and calibre which performed totally differently - one gave the best results when loaded with a fast powder, the other with a slow one. There is no single “magic” recipe which will guarantee good results with any rifle. Safety and common sense dictate that, where no starting load is listed, we start with a load between 7% and 10% below the listed maximum and “work up” carefully, increasing by no more than 1/2 grain at a time. To illustrate this here is an example of load development for a BSA 30-06.

The chosen bullet weight was 150 grains, since this particular rifle had shot well with factory loads using that weight of bullet. The powders available were Hercules Reloder 7 and Vihtavuori N140. In theory both are a little fast-burning if one was seeking maximum performance, but since the load was to be used for Blacktail and the occasional Whitetail a reduced-power load was perfectly acceptable, and probably preferable, to reduce meat damage, noise, recoil and wear and tear on the rifle (and hunter!).

The data from the two powder manufacturers only gave maximum loads. The Hercules data listed 41 grains of Reloder 7, giving a velocity of 2,675 fps (generating 2383 ft/lbs muzzle energy); Vihtavuori data showed 50.9 grains of N140, giving 2900 fps (2801 ft/lbs). Both

were more than adequate for the job in hand - but do we really need all this power? High velocities mean heavy recoil, increased barrel wear and more expense on powder. The final choice was to use Reloder 7, as it was readily available.

The starting load was 36.5 grains and a test batch was loaded up, beginning at this level and increasing in 0.5 grain increments, in three-round strings. At the range each string of three rounds was fired and chronographed. It quickly became apparent that groups were tightening as velocities increased, with heavier charges. At 38.5 grains groups were less than 1" and velocities were in the region of 2,500 fps, with very acceptable recoil and no signs of excess pressure. Further increases in charge weight gave higher velocities and, while there were still no signs of excess pressure being generated, group size was increasing and velocity spread was greater.

A further batch of 10 rounds was produced and test-fired, giving an average velocity of 2520 fps, with a standard deviation figure of 11, and a calculated muzzle energy of 2100 ft/lbs - a very acceptable load indeed.

The Nosler, Hornady, Speer, Sierra and Hodgdon manuals all give a range of loadings for this weight bullet in 30-06, any one of which could have been worked up in a similar fashion. In this case, acceptable results were achieved with the first powder tested. This is not always the case. If the first test batch does not produce suitable results then change one component and try again. It may be that a simple change of powder is all that you need, otherwise it may be that a different primer or bullet is required to achieve the full potential of your rifle. But do be realistic - not every hunting rifle is capable of shooting half-minute groups!

BULLET ENERGY TABLE (from Speer No 11 Reloading Manual)

These factors, multiplied by the weight of the bullet give the amount of energy at a given velocity. The left hand column is velocity in hundreds of feet per second, the figures across the top of the tables are velocity in tens of feet per second.

For example if a 150 grain bullet has a velocity of 2,500 fps you locate 2500 in the left hand column. The factor in the column headed '00', 13.88 multiplied by 150 gives 2802, the bullet energy in foot pounds. If instead a bullet of the same weight has a velocity of 2540 fps you now look across to the figure in the column headed '40', the factor given is '14.32'. Multiply this by 150 and you find that the energy is now 2148 ft. lbs.

ENERGY PER GRAIN OF BULLET WEIGHT

Vel fps	0	10	20	30	40	50	60	70	80	90
1600	5.68	5.75	5.82	5.9	5.97	6.04	6.12	6.19	6.26	6.34
1700	6.41	6.49	6.57	6.64	6.72	6.8	6.88	6.95	7.03	7.11
1800	7.19	7.27	7.35	7.43	7.51	7.6	7.68	7.76	7.84	7.93
1900	8.01	8.1	8.18	8.27	8.35	8.44	8.53	8.61	8.7	8.79
2000	8.88	8.97	9.06	9.15	9.25	9.32	9.42	9.5	9.6	9.7
2100	9.8	9.9	9.98	10.07	10.17	10.26	10.36	10.45	10.55	10.65
2200	10.74	10.84	10.94	11.04	11.14	11.24	11.34	11.44	11.54	11.64
2300	11.74	11.83	11.95	12.05	12.16	12.26	12.37	12.47	12.58	12.68
2400	12.78	12.9	13	13.11	13.22	13.33	13.44	13.55	13.66	13.77
2500	13.88	13.99	14.1	14.2	14.32	14.44	14.55	14.67	14.78	14.89
2600	15.01	15.13	15.24	15.36	15.48	15.59	15.71	15.83	15.96	16.07
2700	16.19	16.31	16.43	16.55	16.67	16.79	16.91	17.04	17.16	17.28
2800	17.41	17.53	17.66	17.78	17.91	18.04	18.16	18.29	18.42	18.55
2900	18.67	18.8	18.93	19.06	19.19	19.32	19.45	19.59	19.72	19.85
3000	19.98	20.11	20.25	20.38	20.52	20.65	20.79	20.92	21.06	21.2
3100	21.33	21.47	21.61	21.75	21.89	22.03	22.17	22.31	22.45	22.59
3200	22.73	22.88	23.02	23.16	23.3	23.45	23.59	23.74	23.88	24.03
3300	24.18	24.32	24.47	24.62	24.77	24.91	25.06	25.21	25.36	25.51
3400	25.66	25.81	25.97	26.12	26.27	26.42	26.58	26.73	26.89	27.04
3500	27.2	27.35	27.51	27.66	27.82	27.98	28.13	28.29	28.45	28.61

SECTION 6 - RELOADING SAFETY

While covering equipment, components, the reloading process and the use of reloading data, we have mentioned a number of safety points, but it is important that we finish by looking at safety as a separate subject on its own.

As with rifle handling, so with reloading, safety must *always* be the paramount consideration.

Working Area

The first requirement is a suitable working area, free from disturbances, distractions and debris, an essential for safe reloading. If you are disturbed or distracted while reloading you may miss out a vital part of the process, such as failing to insert a primer, or worse, repeat a step putting a second charge of powder in a case by mistake.

Discarded loading materials, waste etc. must be cleared away before you start, so as not to contaminate your fresh components. Be especially careful with any oil and lubricants as they can contaminate powders and primers.

Components

Only have one set of components out at one time, if you have several different powders or primers on your bench a mix-up is likely.

Pistol primers will fit in rifle cases, but are made of a softer material and will not stand up to the pressures developed in a rifle case.

Also I am sure I do not need to warn you of the danger of filling a case with a fast burning pistol powder instead of a slow burning rifle powder.

Working Routine

Adopt a logical working sequence, get into a set routine and follow it. Lay out your bench in a set manner every time you start reloading.

It is best to work a 'batch' system, where you process a number of cases through each stage i.e. depriming, resizing etc. Using one or more loading blocks can help here, so you can work in batches of 50 or perhaps 100 cases at a time.

Cases

Case preparation is a vital stage, and close inspection, even with new cases is very important. Look carefully for cracks, splits corrosion etc.

Keep your cases clean, they not only look better, but also work better for burnt powder residue lurking in a case can contaminate fresh powder charges. And primer pockets also need cleaning for the same reason.

Case length trimming must not be missed. If a case is over long it can jam in the lead of the barrel and, when fired, cause enormous pressures, or it can get stuck there causing problems with removal. Removing loaded rounds jammed in the chamber of a rifle can be

very hazardous. Wear safety glasses and do not use any undue force.

Any cases which do not pass inspection for any reason should be crushed with a pair of pliers and discarded to prevent further use.

Primers

Safety glasses are *vital* when handling primers. Primers are the most sensitive of the components used and very occasionally accidents occur. Remember you only have one pair of eyes!

Always keep primers in their original containers, which are designed for their safe storage.

When dismantling ammunition you must again be careful of the primer. In particular, don't try to remove a live primer before deactivating it. This is done by putting a couple of drops of oil in the case and leaving it to soak for a few days. Then remove it carefully wearing safety glasses. There is considerable power in a primer so never take risks with them.

Storage

Keep reloading components, especially powder and primers in their original containers. Both are obviously sensitive to temperature, but surprisingly are little affected by damp. Powder, however, is very sensitive to light and if left in bright sunlight in a powder measure it can deteriorate very quickly.

As a general rule you should aim to apply consistent pressure every time to ensure good results.

Keep Alert

Be on the alert for something going wrong at any stage, for example; normally no undue pressure is needed for any part of the reloading process so if you suddenly meet resistance there must be a very good reason, such as a misaligned primer or case.

Think Safety

There is an air of mystery, even distrust where reloading is concerned, by those who are unfamiliar with the process. Provided you pay attention to everything we have covered on this course and apply a little common sense you should be capable of producing safe and accurate handloads. But always remember whether you use handloads or factory ammunition, firearms safety is paramount - the key has got to be common sense.

Don'ts

Never eat and drink while reloading - and never smoke! Make sure you wash your hands once you have finished to get rid of lead, powder and other materials (remember there is lead compound in primers).

Never take any chances with powder. Keep it in its original container and check that you have the right powder before you start. Double-check your data and the setting of your scales, and continue to check both periodically as you work. If you find your scale setting has changed check every powder charge that you have thrown. Better to do this than blow up your rifle.

Never use any powder you are not sure of. Dispose of it carefully. Small amounts can be carefully burned otherwise, it makes a very good garden fertiliser if sprinkled sparingly about.

Never mix powders. The results are totally unpredictable.

Never exceed published data maximums. There is no point in trying to produce 'super loads', they are unlikely to be as accurate as more moderate loads and they will certainly give you and your rifle a lot more punishment. Know pressure signs and always keep a look out for them.

SECTION 7 - HAND-HELD RELOADING TOOLS

The Lee Loader

There are a number of hand held reloading tools on the market, of which the Lee Loader is probably the most common. Hand held tools have a number of advantages that appeal to hunters.

They are small, lightweight and compact; they can be used almost anywhere, they are moderately priced and require little space for storage. If used with care the ammunition produced can be as accurate and reliable as any reloaded using a conventional press or commercially produced.

They do however have a number of disadvantages - they are slower and a bit 'fiddly' to use compared with a press

(Although if your requirements are small this may not matter); the powder measuring scoop provided limits the user's choice of charge weights and powder types that may be used. It is of course quite possible to weigh your charges using your scales if you wish.

Perhaps the major drawback is that cases are only neck sized, which may affect reliability of feeding in some rifles.

Safety is an important consideration, using a hammer with a reloading tool, especially for the priming and crimping stages of the operation looks more than a little hazardous. Provided the manufacturer instructions are followed and

safety glasses are worn the likelihood of accident is no more than with a normal press.

It is important to ensure that:

1. Everything is properly aligned.
2. Only sufficient force to complete the operation is used.
3. Only light hammer blows are used.

The Lyman 310 Reloading Tool

The Lyman 310 reloading tool has been around in one form or another since the mid-1800's and is one of the simplest hand held tools on the market today. The 310 tool, introduced in 1847, consists of a tool handle similar to a set of nutcrackers, a set of four dies and a small adapter die. The great beauty of it is that you can use it anywhere, it is light in weight and it takes up very little space. It can be converted to another calibre just by switching dies and the dies can be used in a conventional press by using an inexpensive adapter.

Like the Lee Loader it only resizes the neck of the case so it is best used only with cases that have already been fired in your rifle, although it may also be used with new cases or cases that have been full-length sized in a press.

Reloading with the 310 tool is very similar to the process using a conventional press and dies and consists of four stages: neck resizing and decapping, inside neck expanding, priming and bullet seating. You do however have less leverage than with a press however the standard advice and warnings still apply.

The first step in preparing the tool for use is to screw the adapter die into the tool handles, making sure that it does not interfere with the extractor hook. Then I would recommend that you spend a little time carefully setting up each die in turn before you start reloading. The instructions included with each set of dies

are very detailed and there is little that can go wrong (although Murphy's law has a habit of interfering).

There are a couple of points that need watching though. First, as already mentioned, make sure the adapter die does not interfere with the extractor hook. The second point is - be careful when setting up the decapping pin as it is very easily damaged. It is well worthwhile having a couple of spares on hand. Next make sure the extractor hook is properly adjusted and working correctly otherwise, you may be faced with a case jammed in the die.

The neck expanding die needs careful setting up to make sure that the neck is not over-expanded. There is a step at the top of the expanding plug which can be set to expand the neck of the case slightly over bullet diameter to make bullet seating easier,, don't overdo it! (Obviously your cases will need to be trimmed to the same length).

Set up the priming die so that the primer is seated at the bottom of the pocket and flush, or slightly below the case head. This is a step that needs extra care and I would stress that you should always wear eye protection. It is well worth making sure that the primer pocket is cleaned out and no grit or dirt remains that could prevent the primer seating properly.

When setting up the bullet seating die it is useful to make up a dummy round (no primer or powder) to keep for future reference. It can also be used to check that the finished round fits your rifle. You would do well to heed the advice in the instructions to keep the die uppermost when using the tool to avoid powder spilling into the die and to ensure accurate bullet alignment. Finally, after reloading make sure that you clean all traces of sizing lubricant from the case.

A large number of reloaders have happily used these tools for many years. The quality of ammunition produced can be just as good as with more conventional equipment and there is a considerable bonus if space for working is tight. For a hunter who uses only a small amount of ammunition each year it could prove very attractive. You will however still need other items of equipment for preparing your case and for weighing powder.

Other Hand-Held Tools

There are other hand held presses on the market which use standard dies. The Lee Hand-press, Huntington PortPress and Lyman AccuPress (which can also be bench mounted). All are heftier and bulkier than the Lee Loader or Lyman 310 and could provide a half way house for a reloader with limited space unable to set up a complete workstation

